

1.DIMENSION OUTLINE

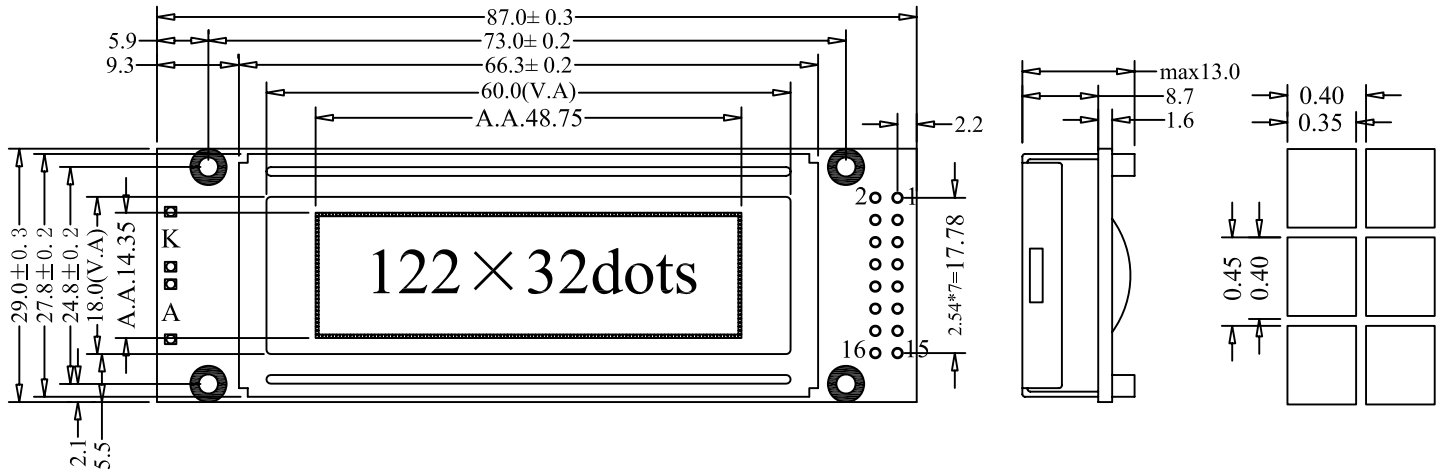

2.MECHANICAL SPECIFICATIONS

ITEM	SPECIFICATIONS	ITEM	REMARK
Module Size(L×W×H)	87.0×29.0×13.0	mm	Reference Dimensional Outline
View Area(W×H)	60.0×18.0	mm	
Effective V/Area(W×H)	48.75×14.35	mm	
Number of Dots	122×32	—	
Dot Pitch(W×H)	0.40×0.45	mm	
Dot Size(W×H)	0.35×0.40	mm	
Weigh(Reflective/LED)	—	g	

3.ABSOLUTE MAXIMUM RATINGS

ITEM	SYMBOL	CONDITION	STANDARD	
			MIN	MAX
Logic Voltage	V _{DD}	Ta=25°C	-0.3V	7V
LCD Voltage	V _{LCD}		-0.3V	13.5V
Input Voltage	V _I		-0.3V	V _{DD} +0.3V
Operation Temperature	T _{OP}	—	-20°C	70°C
Storage Temperature	T _{ST}	—	-20°C	80°C

4.BLOCK DIAGRAM MECHANICAL

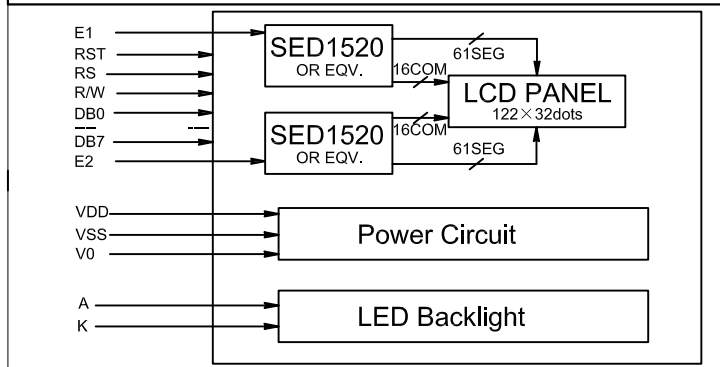

5.LED BACKLIGHT SPECIFICATIONS

ITEM	SYMBOL	TYPE	MAX	UNIT
Ta=25°C				
Forward Voltage	V _f	4.1	4.3	V
Forward Current	I _f	90	—	mA
Emission Wave Length	λ _p	572	—	nm

6.INTERFACE PIN CONNECTIONS

ITEM	SYMBOL	LEVEL	FUNCTIONS
1	VDD	+5V	Power Supply For Logic
2	VSS	0V	Power Ground
3	V0	—	Contrast adjust
4	RST	H/L	Reset Signal
5	E1	H/L	Enable Signal For Chip A
6	E2	H/L	Enable Signal For Chip B
7	R/W	H/L	H:read L:write
8	RS	H/L	H:data L:command
9-16	DB0-DB7	H/L	Data Bus

7.ELECTRICAL CHARACTERISTICS

ITEM	SYMBOL	MIN	TYPE	MAX	UNIT
Ta=25°C					
Logic Power	V _{DD}	4.5	5	5.5	V
Input High Voltage	V _{IH}	2	—	V _{DD}	V
Input Low Voltage	V _{IL}	0	—	0.8	V
Output High Voltage	V _{OH}	2.4	—	V _{DD}	V
Output Low Voltage	V _{OL}	0	—	0.4	V
Logic Current	I _{DD}	—	—	1.5	mA
Operation Voltage For LCD	V _{DD-V0}	—	4.8	—	V